

# ROGUE® PRO

Assembly Guide  
Guide d'assemblage  
Guía de ensamblaje  
Montageanleitung

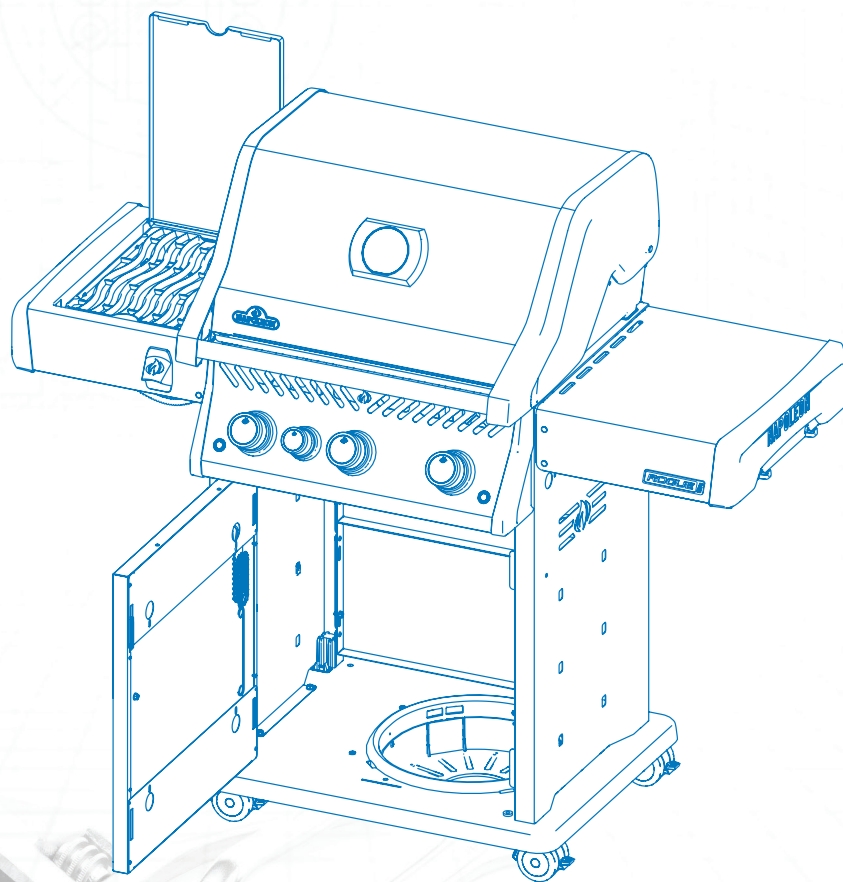

Models | Modèles | Modelos | Modelle

RP425 SIB-2



(EN) Assembly Guidelines | (FR) Guide de montage | (ES) Guía de instalación |  
 (DK) Retningslinjer for montering | (DE) Leitlinien für die Montage |  
 (FI) Kokoonpano-ohjeet | (CZ) Pokyny pro montáž | (SK) Pokyny pre montáž |  
 (SI) Smernice za montažo | (SE) Monteringsanvisningar | (UA) Посібник  
 з монтажу | (PL) Wytyczne dotyczące montażu | (NO) Retningslinjer for  
 montering | (NL) Richtlijnen voor montage | (IT) Linee guida per l'assemblaggio  
 (HR) Smjernice za sastavljanje | (GR) Οδηγίες συναρμολόγησης

- |                                  |                             |
|----------------------------------|-----------------------------|
| (EN) Safety requirements         | (SE) Säkerhetskrav          |
| (FR) Exigences de sécurité       | (UA) Вимоги безпеки         |
| (ES) Requerimientos de seguridad | (PL) Wymogi bezpieczeństwa  |
| (DK) Krav til sikkerhed          | (NO) Sikkerhetskrav         |
| (DE) Sicherheitsanforderungen    | (NL) Veiligheidseisen       |
| (FI) Turvallisuusvaatimukset     | (IT) Requisiti di sicurezza |
| (CZ) Bezpečnostní požadavky      | (HR) Sigurnosni zahtjevi    |
| (SK) Bezpečnostné požiadavky     | (GR) Απαιτήσεις ασφαλείας   |
| (SI) Varnostne zahteve           |                             |



- |                                                      |                                                                |
|------------------------------------------------------|----------------------------------------------------------------|
| (EN) Installation tools (not included)               | (SE) Installationsverktyg (ingår ej)                           |
| (FR) Outils d'installation (non inclus)              | (UA) Інструменти для встановлення<br>(не входять до комплекту) |
| (ES) Herramientas de instalación<br>(no incluidas)   | (PL) Narzędzia montażowe<br>(brak w zestawie)                  |
| (DK) Installationsværktøj (medfølger ikke)           | (NO) Installasjonsverktøy (ikke inkludert)                     |
| (DE) Montagewerkzeug (nicht enthalten)               | (NL) Installatiegereedschap<br>(niet meegeleverd)              |
| (FI) Asennustyökalut (eivät sisälly)<br>baleni)      | (IT) Strumenti di installazione (non inclusi)                  |
| (CZ) Instalační nářadí (není součástí<br>balení)     | (HR) Alati za instalaciju (nisu uključeni)                     |
| (SK) Inštaláčne náradie<br>(nie je súčasťou dodávky) | (GR) Εργαλεία εγκατάστασης<br>(δεν περιλαμβάνονται)            |
| (SI) Orodja za namestitvev (niso vključena)          |                                                                |



3/8  
(10 mm)

3/8  
(10 mm)

T30  
TORX

Legend | Légende | Leyenda | Legende | Legende | Selite | Legenda  
 Legenda | Legenda | Legend | Легенда | Legenda | Legende | Legende  
 Legenda | Legenda | Υπόμνημα

	Warning! Avertissement ! ¡Advertencia! Advarsel! Warnung!	Varoitus! Varován! Varovanie! Opozorilo! Varning!	Обережно! Ostrzeżenie! Advarsel! Waarschuwing! Attenzione!	Upozorenje! Προειδοποίηση!
	Caution! Attention ! ¡Precaución! Forsigtig! Vorsicht!	Varoitus! Pozor! Pozor! Varning! Обережно!	Uwaga! Forsiktig! Let op! Attenzione! Oprez!	Προσοχή!
	Lock Bloc Bloquear Låse	Sperren Lukko Zámek Zámok	Zaklepanje Låsa Замок Zamek	Slot Serratura Brava Κλειδαριά
	Positioning Positionnement Posicionamiento Positionering Positionierung Paikannus	Polohování Polohovanie Pozicioniranje Positionering Позиціонування Pozycjonowanie		Positionering Posizionamento Pozicioniranje Τοποθέτηση
	Use rubber mallet Utiliser un maillet en caoutchouc Use un mazo de goma Slå med gummihammer Mit Gummihammer schlagen Käytä kumivasaraa Použijte gumovou paličku Použite gumenú paličku Uporabite gumijasto kladivo		Använd gummiklubba Використовуйте гумовий молоток Użyj gumowego młotka Bruk gummihammer Gebruik een rubberen hamer Usa un martello di gomma Koristite gumeni čekić Χρησιμοποιήστε λαστιχένια σφύρα	
	Rotate the Unit Rotation de l'appareil Rotar la unidad Drej enheden Drehen Sie das Gerät Kierrä yksikköä	Otočte jednotku Otočte jednotku Zavrtite enoto Vrid enheten Обертайте пристрій Obróć urządzenie		Roter enheten Draai de eenheid Ruotare l'unità Okrenite jedinicu Περιστρέψτε τη μονάδα

Legend | Légende | Leyenda | Legende | Legende | Selite | Legenda |  
 Legenda | Легенда | Legende | Legende | Leggenda | Legenda | Υπόμνημα



Propane Only  
 Propane uniquement  
 Sólo propano  
 Kun propan  
 Nur Propan  
 Vain propaani

Pouze propan  
 Iba propán  
 Samo propan  
 Endast propan  
 Тільки пропан  
 Tylko propan

Kun propan  
 Alleen propaan  
 Solo propano  
 Samo propan  
 Μόνο προπάνιο



Natural Gas  
 Gaz naturel  
 Gas natural  
 Naturgas  
 Erdgas  
 Maakaasu

Zemní plyn  
 Zemný plyn  
 Zemeljski plin  
 Naturgas  
 Природний газ  
 Gazu ziemnego

Naturgass  
 Natuurlijk gas  
 Gas naturale  
 Prirodni gas  
 Φυσικό αέριο



Side Burner  
 Brûleur latéral  
 Quemador lateral  
 Sidebrænder  
 Seitenbrenner  
 Sivupoltin

Boční hořák  
 Bočný horák  
 Stranski gorilnik  
 Sidobrännare  
 Бічний пальник  
 Palnik boczny

Sidebrenner  
 Zijbrander  
 Fornello laterale  
 Bočni plamenik  
 Πλαϊνός καυστήρας



Non - Side Burner  
 Sans brûleur latéral.  
 Sin quemador lateral.  
 Uden - Sidebrænder  
 Ohne -  
 Seitenbrenner  
 Ilman sivupoltinta

Bez bočního hořáku  
 Bez bočného horáka  
 Brez stranskega  
 gorilnika  
 Utan sidobrännare  
 Без бічної конфорки  
 Bez palnika bocznego

Uten sidebrenner  
 Zonder zijbrander  
 Senza fornello laterale  
 Bez bočnog plamenika  
 Χωρίς Πλαϊνό  
 Καυστήρα



Remove film.  
 Retirer le film.  
 Retire la película  
 Fjern film  
 Folie entfernen  
 Poista kalvo

Odstraňte fólii  
 Odstráňte film  
 Odstranite film  
 Ta bort filmen  
 Зняти плівку  
 Usuń folię

Fjern filmen  
 Verwijder folie  
 Rimuovere la  
 pellicola  
 Uklonite film  
 Αφαιρέστε το φιλμ



Caution Head Injury  
 Attention blessure à la  
 tête  
 Atención lesión craneal  
 Forsiktig Hovedskade  
 Vorsicht  
 Kopfverletzung

Varoitus Pään vamma  
 Pozor Poranění hlavy  
 Pozor Poranenie hlavy  
 Pozor Poškodba glave  
 Varning Huvudskada  
 Bez bichnoyi konforky  
 Uwaga, uraz głowy

Forsiktig Hodeskade  
 Let op hoofdletsel  
 Attenzione ferita alla testa  
 Oprez Ozljeda glave  
 Προσοχή  
 Τραυματισμός στο  
 κεφάλι

# WELCOME TO NAPOLEON!

Congratulations on upgrading your grilling game and welcome to the **NAPOLEON** family!



Ready to assemble your new grill?



There may be visual differences between illustrations and model purchased. Remove all parts from packaging before assembling the barbecue. Set up this assembly on a solid, level and horizontal surface.

# BIENVENUE À NAPOLEON!

Félicitations pour votre achat et bienvenue dans la famille **NAPOLEON!**



Prêt à assembler votre nouveau grill?



Veillez noter qu'il peut y avoir des différences entre les illustrations de ce guide et le modèle acheté. Retirez toutes les pièces de leur emballage avant de commencer. Veillez à assembler votre grill sur une surface plane et solide.

# ¡BIENVENIDO A NAPOLEON!

¡Felicidades por mejorar tu juego de parrilla y bienvenido a la familia **NAPOLEON!**



¿Listo para ensamblar tu nueva parrilla?



Tenga en consideración que puede haber diferencias entre las ilustraciones en esta guía y el modelo adquirido. Remueva todas las piezas de sus empaques antes de comenzar. Asegúrese de ensamblar la parrilla en una superficie plana y sólida.

# VELKOMMEN TIL NAPOLEON!

Tillykke med, at du har opgraderet dit grillspil, og velkommen til **NAPOLEON**-familien!



Er du klar til at samle din nye grill?



Der kan være visuelle forskelle mellem illustrationer og den købte model. Tag alle dele ud af emballagen, før du samler grillen. Stil grillen op på en solid, plan og vandret overflade.

## WILLKOMMEN BEI NAPOLEON!

Herzlichen Glückwunsch zur Aufrüstung Ihres Grills und willkommen in der **NAPOLEON**-Familie!



Sind Sie bereit, Ihren neuen Grill zusammenzubauen?



Es kann optische Unterschiede zwischen den Abbildungen und dem gekauften Modell geben. Nehmen Sie vor dem Zusammenbau des Grills alle Teile aus der Verpackung. Stellen Sie die Baugruppe auf einer festen, ebenen und horizontalen Fläche auf.

## TERVETULOA NAPOLEONIIN!

Onnittelut grillauspelisi päivittämisestä ja tervetuloa **NAPOLEON**-perheeseen!



Oletko valmis kokoamaan uuden grillisi?



Kuvissa ja ostetussa mallissa voi olla visuaalisia eroja. Poista kaikki osat pakkauksesta ennen grillin kokoamista. Aseta tämä kokoonpano kiinteälle, tasaiselle ja vaakasuoralle alustalle.

## VÍTEJTE V NAPOLEONU!

Blahopřejeme vám k vylepšení vaší grilovací hry a vítáme vás v rodině **NAPOLEON!**



Jste připraveni sestavit svůj nový gril?



Mezi ilustracemi a zakoupeným modelem mohou být vizuální rozdíly. Před sestavením grilu vyjměte všechny díly z obalu. Tuto sestavu postavte na pevný, rovný a vodorovný povrch.

## VITAJTE V NAPOLEONE!

Blahoželáme vám k vylepšeniu vašej grilovacej hry a vítame vás v rodine **NAPOLEON!**



Ste pripravení zostaviť svoj nový gril?



Medzi ilustráciami a zakúpeným modelom môžu byť vizuálne rozdiely. Pred zostavením grilu vyberte všetky diely z obalu. Túto zostavu postavte na pevný, rovný a vodorovný povrch.

## DOBRODOŠLI V NAPOLEONU!

Čestitamo vam, da ste izboljšali svojo igro na žaru, in vas pozdravljamo v družini **NAPOLEON!**



Ste pripravljeni na montažo svojega novega žara?



Med ilustracijami in kupljenim modelom so lahko vizualne razlike. Pred sestavljanjem žara odstranite vse dele iz embalaže. Ta sklop postavite na trdno, ravno in vodoravno površino.

## VÄLKOMMEN TILL NAPOLEON!

Grattis till att du har uppgraderat din grillning och välkommen till **NAPOLEON**-familjen!



Är du redo att montera din nya grill?



Det kan förekomma visuella skillnader mellan illustrationer och den modell som köpts. Ta bort alla delar från förpackningen innan du monterar grillen. Ställ upp enheten på ett stabilt, plant och horisontellt underlag.

## ЛАСКАВО ПРОСИМО НА НАПОЛЕОН!

Вітаємо з оновленням вашого гриля та ласкаво просимо до сім'ї **NAPOLEON**!



Готові зібрати свій новий гриль?



Можливі візуальні відмінності між ілюстраціями та придбаною моделлю. Вийміть всі деталі з упаковки, перш ніж збирати гриль. Встановіть цю збірку на тверду, рівну і горизонтальну поверхню.

## WITAMY W NAPOLEON!

Gratulujemy ulepszenia swojego grilla i witamy w rodzinie **NAPOLEON**!



Gotowy do montażu nowego grilla?



Mogą występować różnice wizualne między ilustracjami a zakupionym modelem. Przed złożeniem grilla należy wyjąć wszystkie części z opakowania. Ustaw urządzenie na solidnej, równej i poziomej powierzchni.

## VELKOMMEN TIL NAPOLEON!

Gratulerer med oppgraderingen av grillspillet ditt, og velkommen til **NAPOLEON**-familien!



Er du klar til å montere din nye grill?



Det kan være visuelle forskjeller mellom illustrasjonene og modellen du har kjøpt. Ta alle delene ut av emballasjen før du monterer grillen. Sett opp denne enheten på en solid, jevn og vannrett overflate.

## WELKOM BIJ NAPOLEON!

Gefeliciteerd met het upgraden van uw grill spel en welkom bij de **NAPOLEON** familie!



Klaar om uw nieuwe grill te monteren?



Er kunnen visuele verschillen zijn tussen de illustraties en het gekochte model. Haal alle onderdelen uit de verpakking voordat u de barbecue in elkaar zet. Zet dit geheel op een stevige, vlakke en horizontale ondergrond.

## BENVENUTO A NAPOLEON!

Congratulazioni per aver migliorato il vostro gioco di grigliate e benvenuti nella famiglia **NAPOLEON**!



Siete pronti ad assemblare il vostro nuovo grill?



Potrebbero esserci differenze visive tra le illustrazioni e il modello acquistato. Rimuovere tutte le parti dall'imballaggio prima di assemblare il barbecue. Posizionare il gruppo su una superficie solida, piana e orizzontale.

## DOBRODOŠLI U NAPOLEON!

Čestitamo na unapređenju vaše igre roštiljanja i dobrodošli u **NAPOLEON** obitelj!



Spremni za sastavljanje vašeg novog roštilja?



Može biti vizualnih razlika između ilustracija i kupljenog modela. Uklonite sve dijelove iz pakiranja prije sastavljanja roštilja. Postavite ovu montažu na čvrstu, ravnu i vodoravnu površinu.

## ΚΑΛΩΣ ΗΛΘΑΤΕ ΣΤΟ NAPOLEON!

Συγχαρητήρια για την αναβάθμιση του παιχνιδιού ψησίματος και καλωσορίσατε στην οικογένεια **NAPOLEON**!



Είστε έτοιμοι να συναρμολογήσετε τη νέα σας ψησταριά;



Ενδέχεται να υπάρχουν οπτικές διαφορές μεταξύ των απεικονίσεων και του μοντέλου που αγοράσατε. Αφαιρέστε όλα τα εξαρτήματα από τη συσκευασία πριν συναρμολογήσετε το μπάμπεκιου. Τοποθετήστε αυτό το συγκρότημα σε μια σταθερή, επίπεδη και οριζόντια επιφάνεια.



Model | Modèle | Modelo | Modelle

RP425

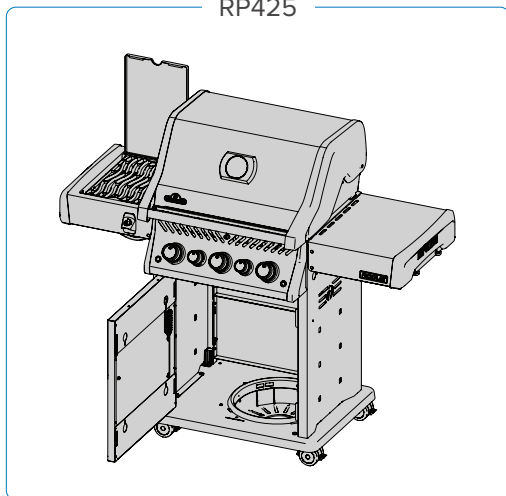



**Assembly Steps**  
**Étapes d'assemblage**  
**Pasos para la instalación**  
**Montageschritte**

1

 x4

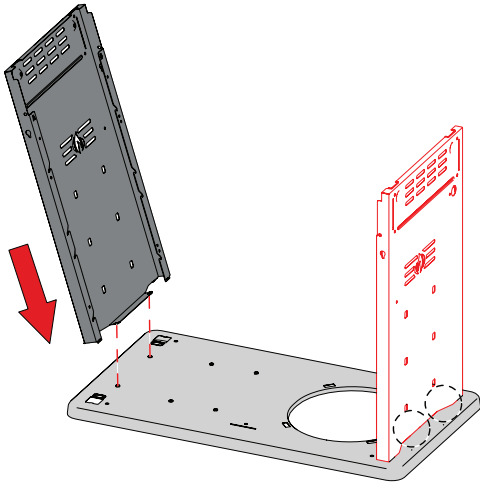
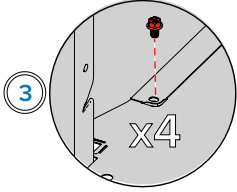
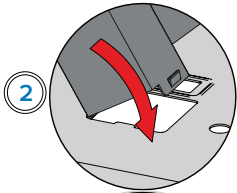
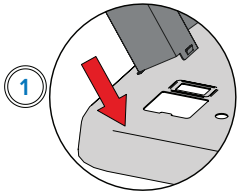

2

 x8

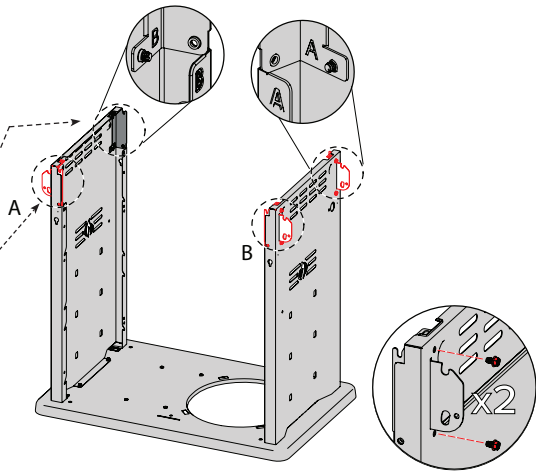
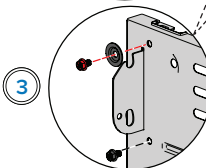
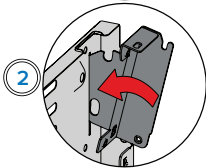
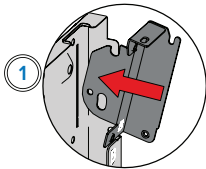



3

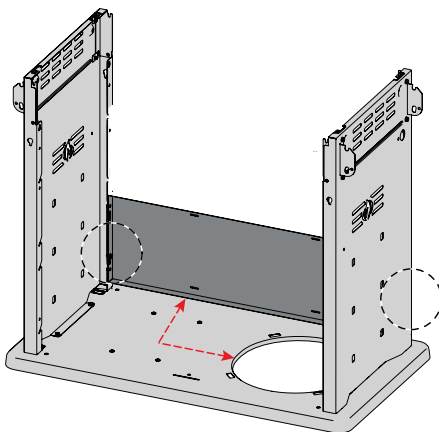
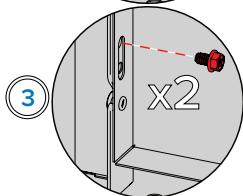
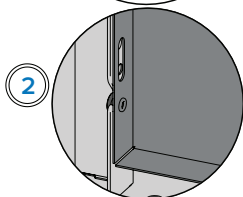
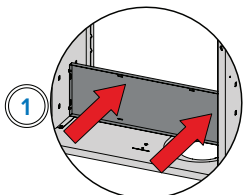

4

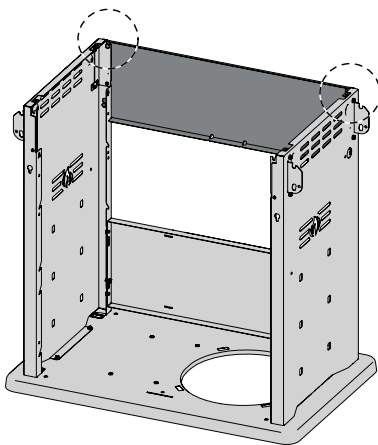
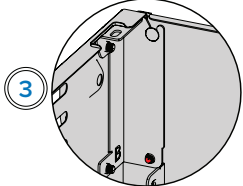
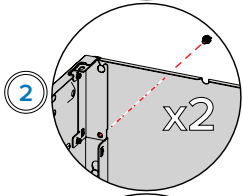
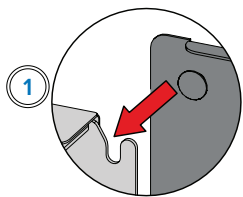

5

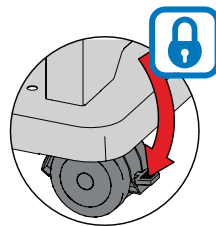
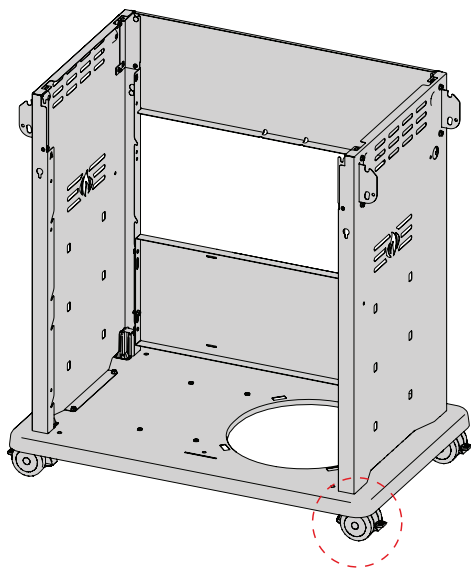
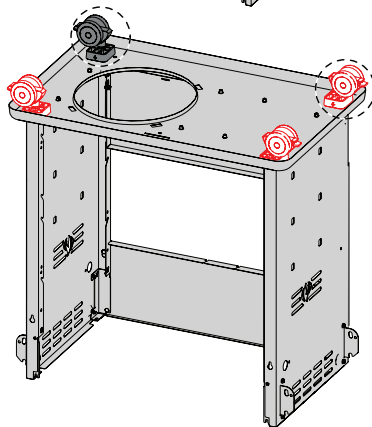
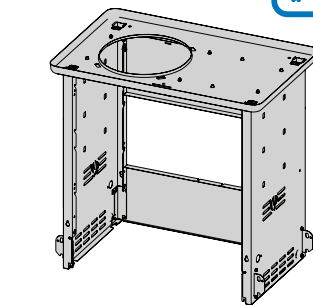
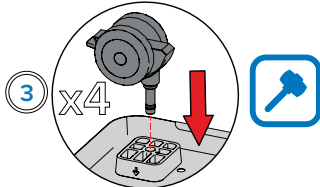
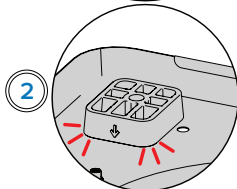
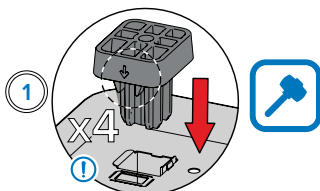

6

 x4

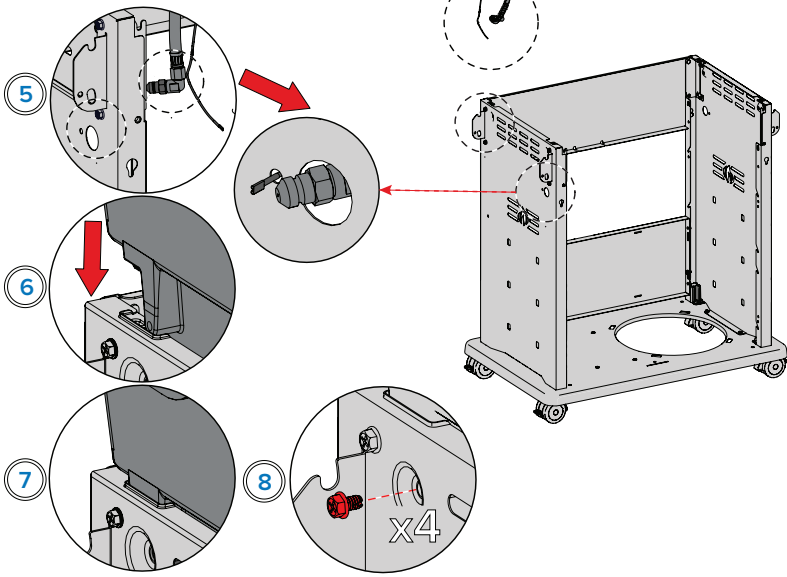
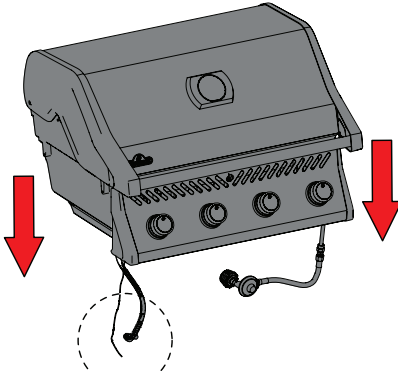
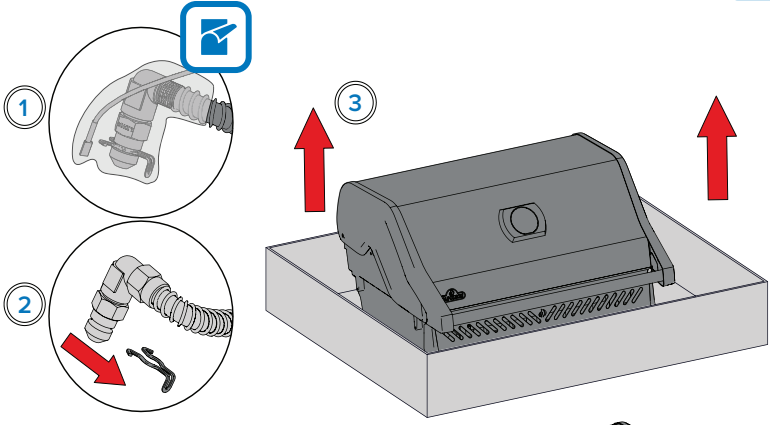



9

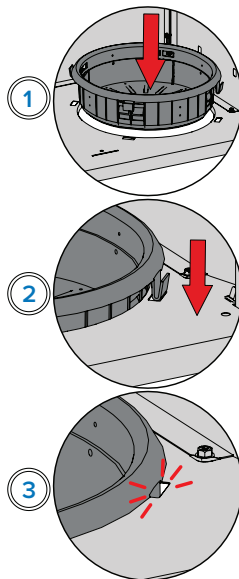
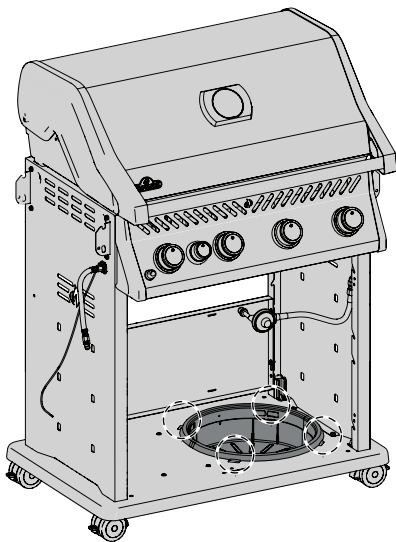

10

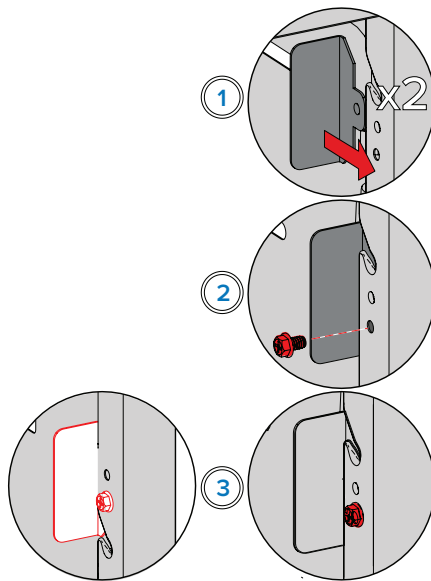
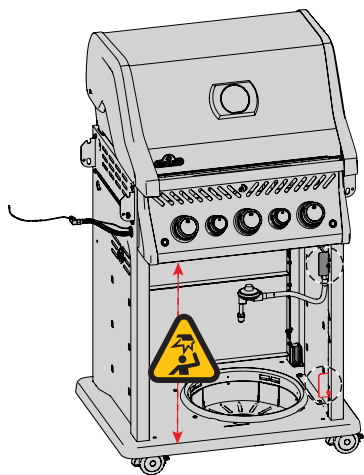

11

 x2

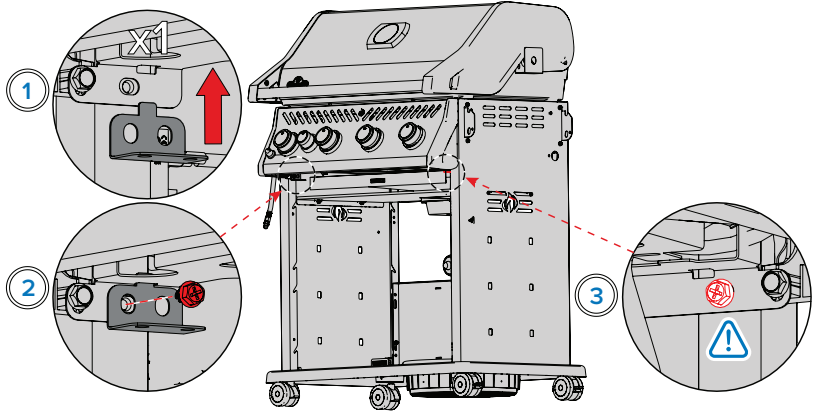

12



 x4 (425)

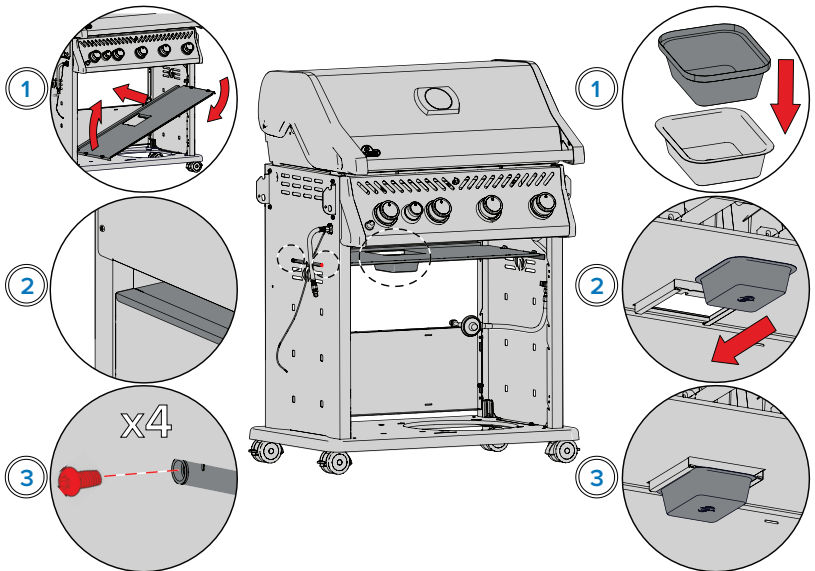



13

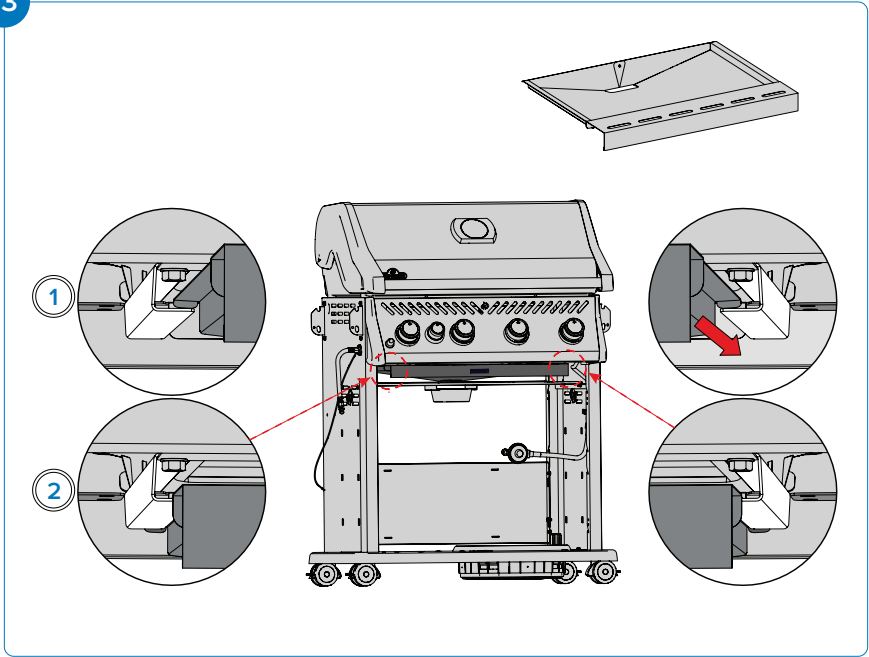

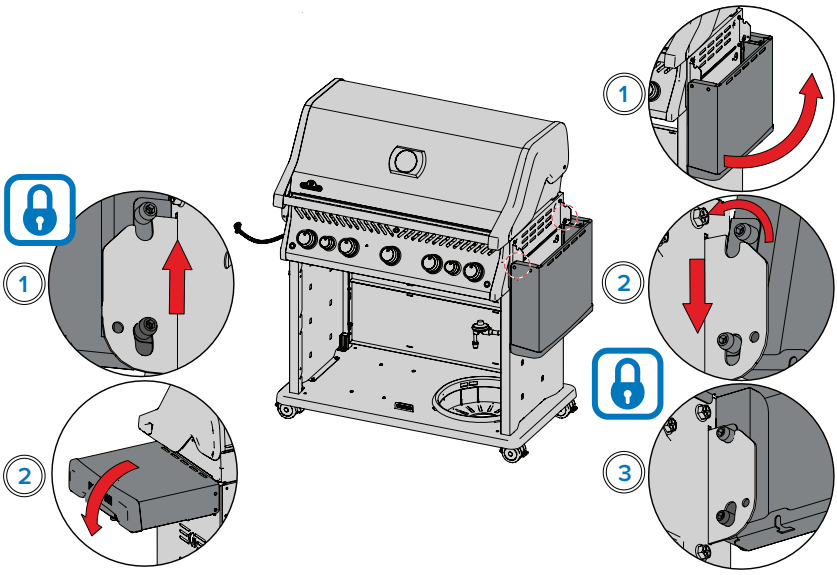
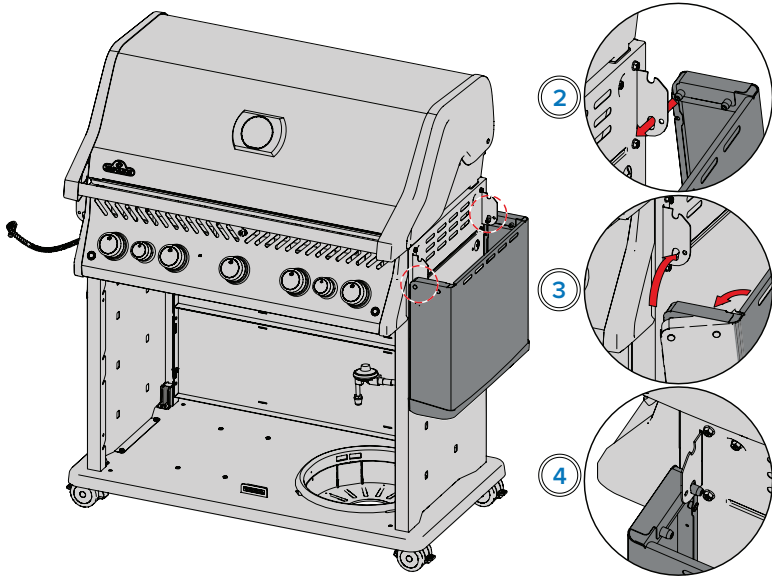

15

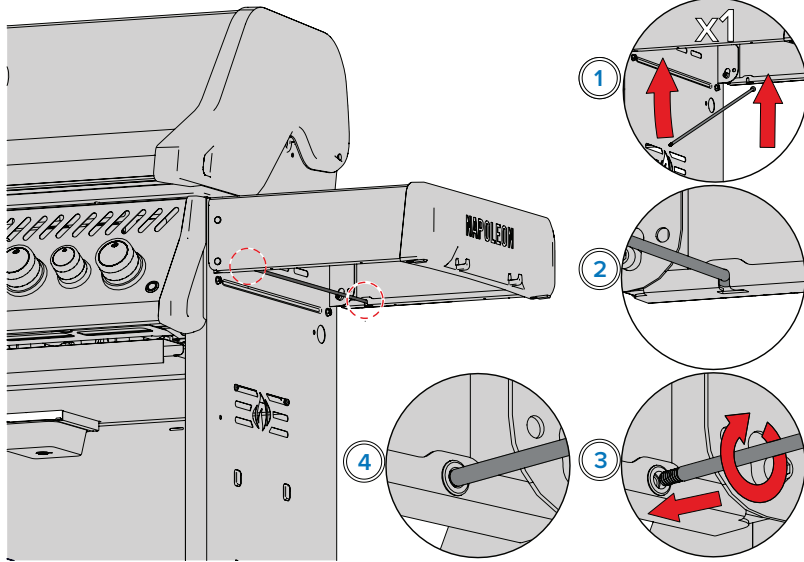

16

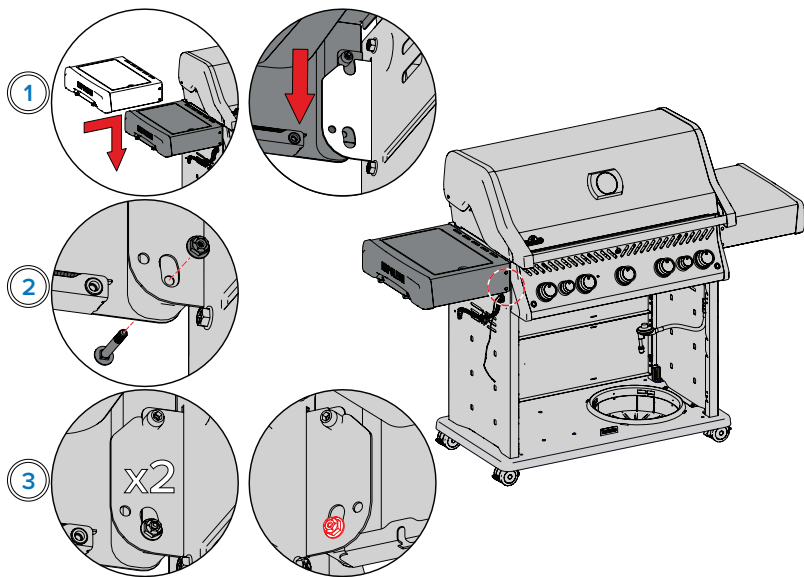

17

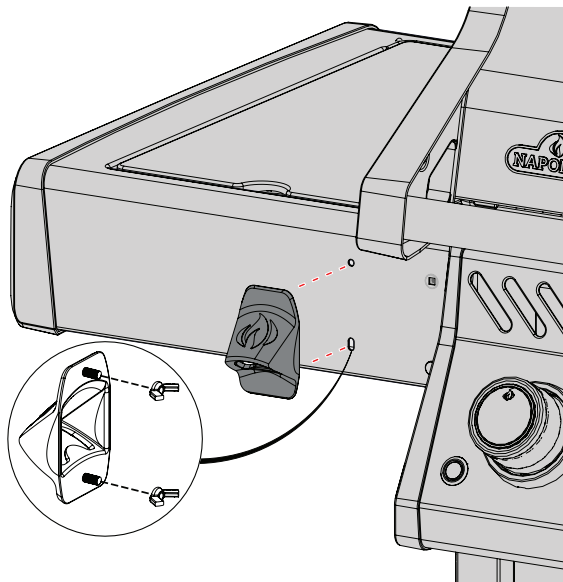

18

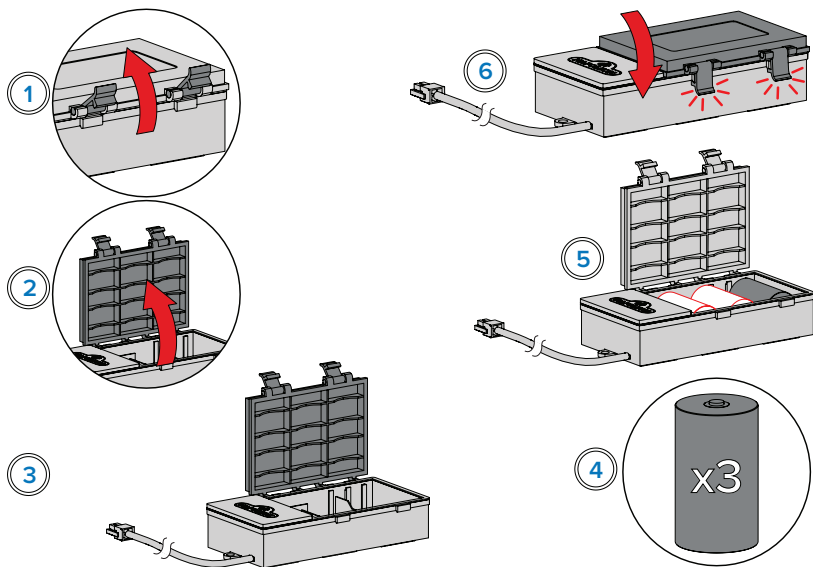



19

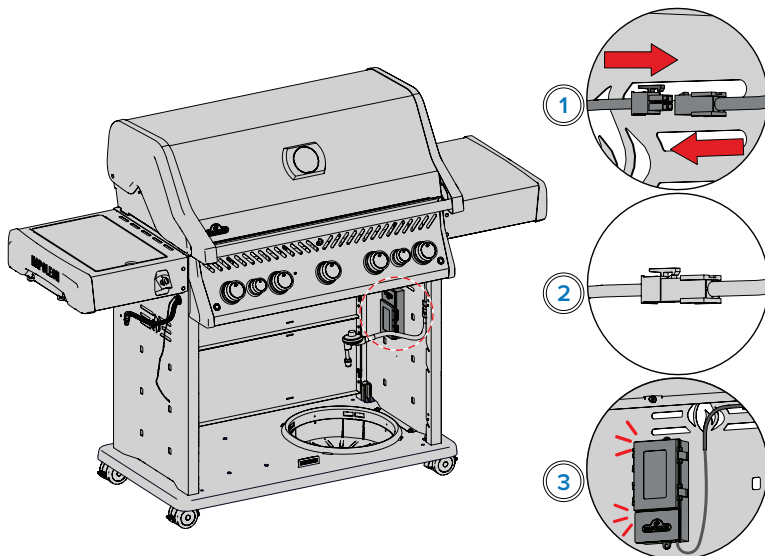

20

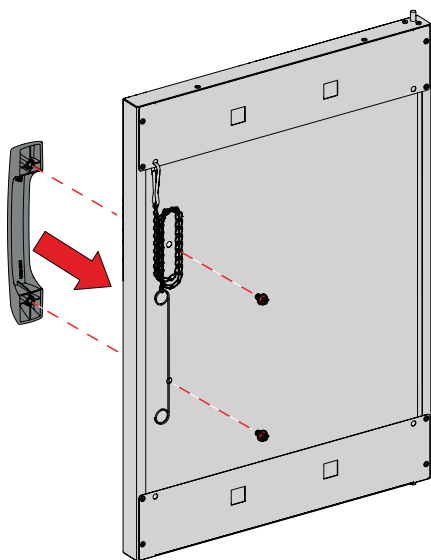

21

 x1

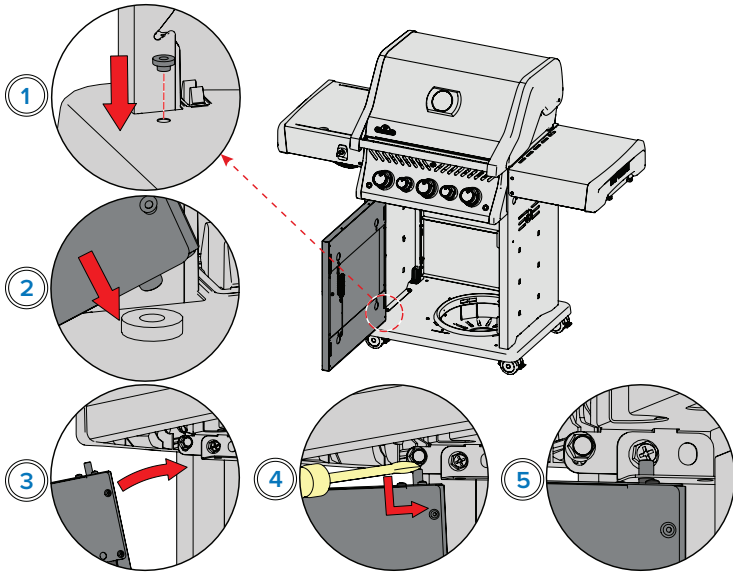

22

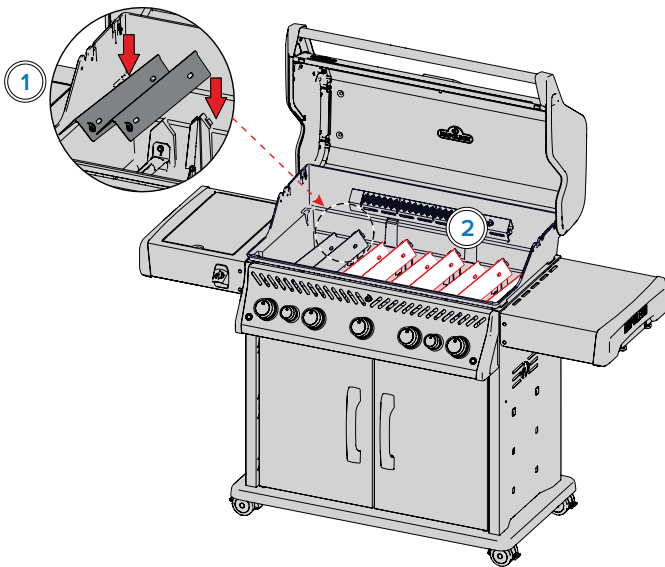

23

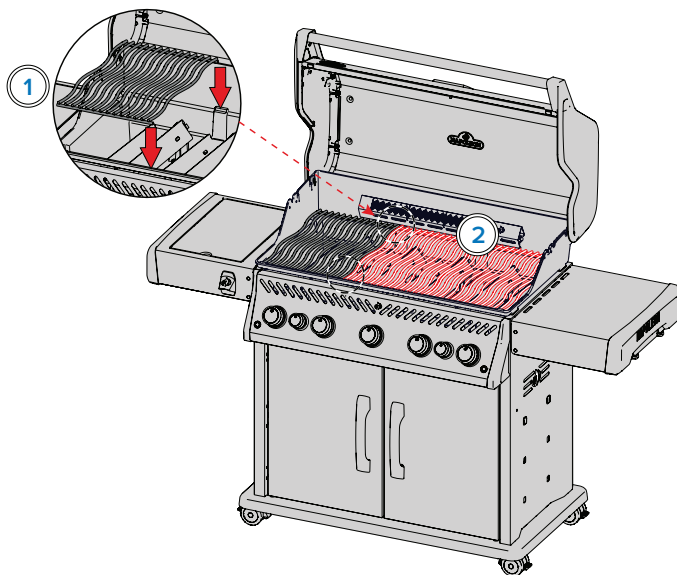

24

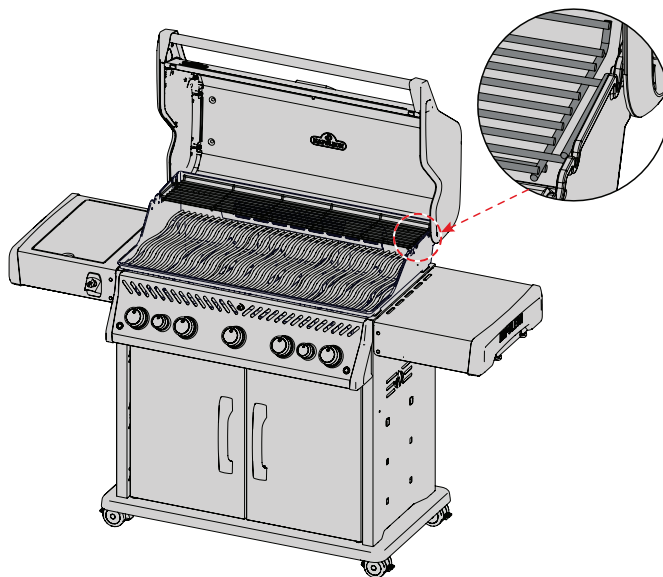

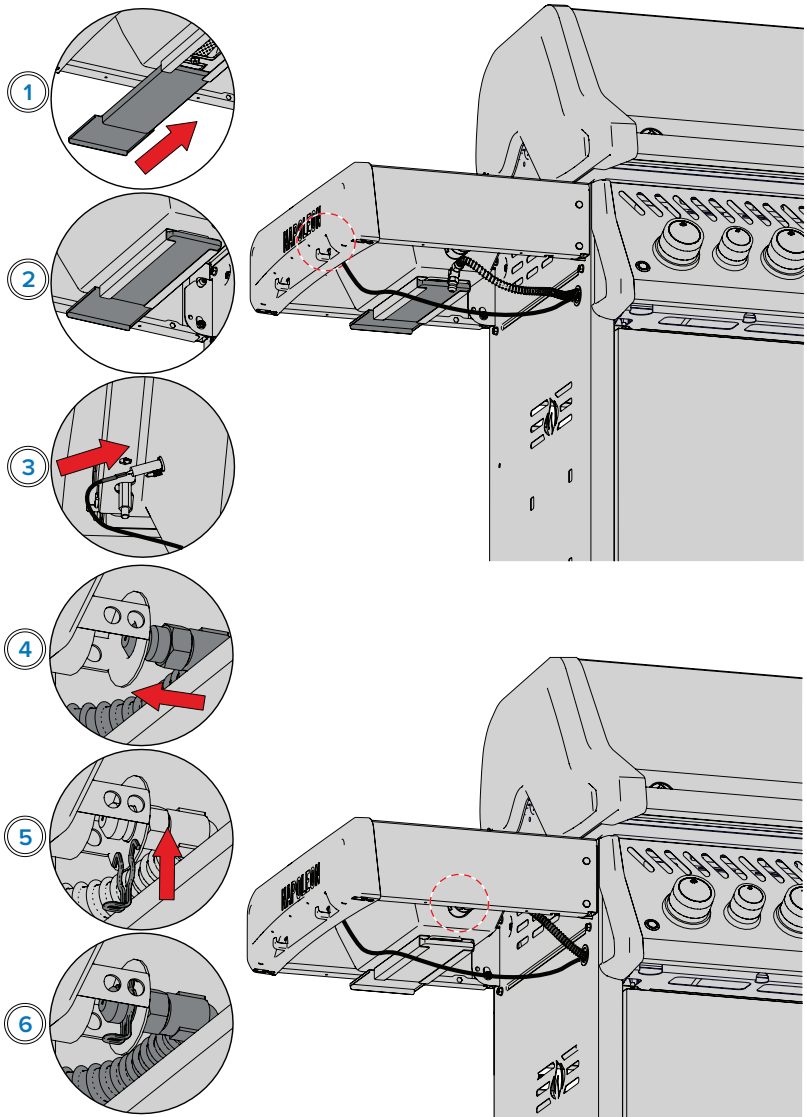

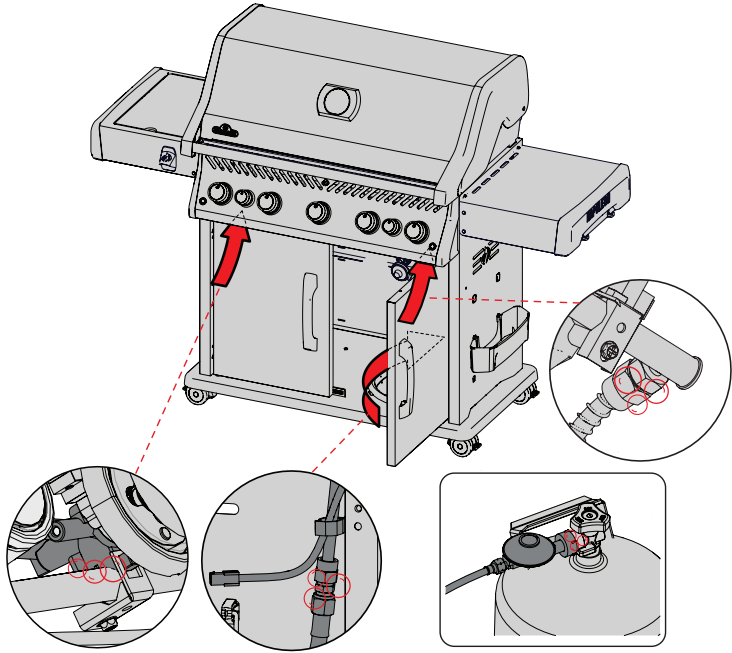
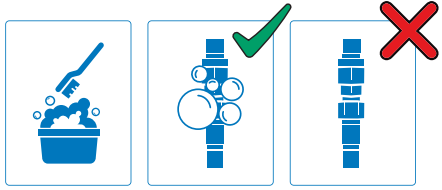



**Parts List**

**Liste des pieces**

**Lista de piezas**

**Liste der Einzelteile**



## Legend | Légende | Leyenda | Legende

Legend	Légende	Leyenda	Legende
x - standard part	x - standard	x - estándar	x - standardteil
p - propane	p - propane	p - propano	p - propan
n - natural gas	n - gas naturel	n - gas natural	n - erdgas
ac - accessory	ac - accessoire	ac - accesorio	ac - zubehörtel
alt - alternate	alt - alternatif	alt - alternativa	alt - alternativ

	Part # Partie # Parte # Teil #	RP425SIB	Description   Description Descripción   Beschreibung
1	N010-1754-SS	x	Stainless Steel Lid Assembly Assemblage du couvercle en acier inoxydable Set de ensamblado de la tapa de acero inoxidable Edelstahl-Deckel-Montage
	N010-1754-BK	x	Black Lid Assembly   Assemblage du couvercle noire Set de ensamblado de la tapa, color negro Schwarzer Deckel Montage
	N010-1754-CH	x	Charcoal Lid Assembly   Assemblage du couvercle pour charbon de bois   Montage de la tapa de carbón Montage des Holzkohlendeckels
2	S91015	x	Temperature Gauge   Jauge de température Indicador de temperatura   Temperaturanzeige
3	N385-0513-SER	x	Napoleon Logo   Logo Napoléon Logo Napoleón   Napoleon-Logo
4	N510-0013	x	Rectangular Bumper   Pare-chocs rectangulaire Parachoques rectangular   Rechteckiger Stoßfänger
5	S87014	x	Pivot Lid   Couvercle pivotant Tapa pivotante   Schwenkdeckel
6	N010-1041-SER	x	Base Casting Assembly Assemblage de la base de coulée Conjunto de fundición base   Sockel Guss Montage
7	S87010	x	Cross Light Bracket   Support d'éclairage transversal Soporte de luz transversal   Kreuzlichthalterung
8	N080-0423	x	Cross Light Folding Bracket Support pliant pour feux de croisement Soporte plegable de luz transversal Kreuzlicht-Klappbügel
9	S87001	x	Sear Burner Kit   Kit brûleur de cuisson Kit quemador para dorar   Anbratbrenner-Kit
10	N305-0108	x	Sear Plate   Plaque de séchage Placa Sear   Anbratplatte
11	N100-0060	x	Main Burner Tube   Tube du brûleur principal Tubo del quemador principal   Hauptbrennerrohr
11*	N100-0060-IL	alt	Main Burner Tube   Tube du brûleur principal Tubo del quemador principal   Hauptbrennerrohr
12	N520-0055	x	Warming Rack   Support de réchauffage
	71501	ac	Rejilla para calentar   Warmhaltegestell
13	S83043	x	Stainless Steel Grids   Grilles en acier inoxydable Rejillas de acero inoxidable   Roste aus rostfreiem Stahl

	Part # Partie # Parte # Teil #	RP425SIB	Description   Description Descripción   Beschreibung
	S83008	x	Cast Iron Grids   Grilles en fonte Rejillas de hierro fundido   Gusseisen-Gitterroste
14	N200-0118-GY1SG	x	Base Back Cover   Couvercle arrière de la base Tapa trasera de la base   Basis Rückwand
15	N585-0145-GY1SG	x	Heat Cart Shield   Bouclier thermique Escudo térmico   Wärmewagen-Schild
16	N570-0145-GY	x	Screw   Vis   Tornillo   Schraube
17	N710-0062	x	Grease Tray   Bac à graisse
	62007	ac	Bandeja de grasa   Fettauffangwanne
18	N475-0363-GY1SG	x	Rear Cart Panel   Panneau arrière du chariot Panel trasero del carro   Hinteres Wagenpaneel
19	N080-0364	x	Shelf Bracket A   Support d'étagère A Soporte de estante A   Regalhalterung A
20	N350-0077LY	x	Battery Housing   Boîtier de batterie Alojamiento de la batería   Batteriegehäuse
21	N710-0094	x	Drip Pan   Bac d'égouttage Bandeja de goteo   Auffangwanne
22	N080-0378-GY1SG	x	Pivot Door Bracket   Support de porte pivotante Soporte de puerta pivotante   Halter für Drehtür
23	N080-0365	x	Shelf Bracket B   Support d'étagère B Soporte de estante B   Regalhalterung B
24	N750-0016	x	Side Burner Ignition Wire Fil d'allumage du brûleur latéral Cable de encendido del quemador lateral Zündkabel für Seitenbrenner
25	N357-0021LY	x	Igniter Box   Boîte d'allumage Caja de Ignición   Anzünd-Box
26	N455-0112	x	Orifice   Orifice   Orificio   Blende
27	N160-0023	x	Orifice Retainer Clip Clip de retenue d'orifice Clip de retención del orificio Halteklammer für die Blende
28	N255-0064	x	Elbow Fitting   Raccord coudé   Codo   Winkelverschraubung
29	N720-0055	x	Flex Hose Assembly Ensemble de tuyau flexible Conjunto de manguera flexible Flexschlauch-Baugruppe
30	W105-0010	x	Bushing   Bague   Amortiguador   Buchse
31	N130-0015	x	Caster   Roue dentée   Rueda   Nachlauf
32	N510-0015	x	Caster Socket   Socle de roulette Zócalo de ruedas   Nachlaufsockel
33	N590-0292-GY1SG	x	Cart Bottom Shelf Tablette inférieure du chariot Estante inferior del carro Unteres Wagenregal

	Part # Partie # Parte # Teil #	RP425SIB	Description   Description Descripción   Beschreibung
34	N475-0607-GY1SG	x	Cabinet Side Panel Panneau latéral de l'armoire Panel lateral del gabinete Seitenwand des Gehäuses
35	N530-0032	x	Propane Regulator   Régulateur de propane Regulador de propano   Propan-Regler
	N530-0033	x	
	N530-0034	x	
	N530-0035	x	
	N530-0036	x	
	N530-0037	x	
	N530-0038	x	
	N530-0039	x	
	N530-0042	x	
	N530-0043	x	
	N530-0046	x	
36	N255-0027	x	Union Fitting   Raccord union Accesorio de unión   Verschraubung
37	N370-0745	ac	Rotisserie Mount Kit   Kit de montage pour rôtissoire Kit de montaje para asador   Rotisserie-Montagesatz
38	N010-1782-SS	x	Large Shelf Assembly Assemblage des grandes étagères Montaje de estanterías grandes Großes Regal Montage
	N010-1782-BK	x	
	N010-1782-SS	x	
39	N370-0928-SER	x	Shelf Kit   Kit d'étagères   Kit de estantes   Regal-Bausatz
40	N385-10001897	x	Rogue PRO Logo   Logo Rogue PRO Logo Rogue PRO   Rogue PRO Logo
41	N080-0380-GY1SG	x	Magnet Bracket   Support magnétique Soporte magnético   Magnet-Halterung
42	N370-0845CE	p	Tank Tray Kit   Kit de plateau de réservoir Kit de bandeja de depósito   Tankwannen-Bausatz
43	N010-0869-SS-SER	x	Single Door Assembly Assemblage de porte simple Conjunto de puerta simple Einzelne Türmontage
	N010-0869-BK-SER	x	
	N010-0869-CH-SER	x	
44	N555-0097	x	Lighting Match Rod   Tige d'allumage Varilla de fósforo   Beleuchtung Streichholzstab
45	N325-0094-SER	x	Door Handle   Poignée de porte Manija de la puerta   Türklinke
46	N105-0011	x	Door Pivot Bushing   Douille de pivot de porte Casquillo pivote de puerta   Türzapfenbuchse
47	N080-0422-SER	x	Bottle Opener   Ouvre-bouteille Abrebotellas   Flaschenöffner

	Part # Partie # Parte # Teil #	RP425SIB	Description   Description Descripción   Beschreibung
48	N010-1781-CE-SS	x	Infrared Burner Shelf Assembly
	N010-1781-CE-BK	x	Ensemble étagère pour brûleur infrarouge
	N010-1781-CE-SS	x	Conjunto de estante del quemador infrarrojo Infrarot-Brennerregal Montage
49	N335-0098-M06	x	Side Burner Lid   Couverture du brûleur latéral
	N335-0098-BK1HR	x	Tapa del quemador lateral   Seitenbrenner-Deckel
50	N305-10001280	x	Wavy Grid   Grille ondulée Parrilla onculada   Gewelltes Raster
51	N010-1428	x	Infrared Burner   Brûleur infrarouge Quemador infrarrojo   Infrarot-Brenner
52	N500-0039K	x	Plate   Assiette   Placa   Platte
53	N240-0026	x	Electrode   Électrode Electrodo   Elektrode
54	N510-0013	x	Rectangular Bumper   Pare-chocs rectangulaire Tope rectangular   Rechteckiger Stoßfänger
55	N080-0358	x	Drip Pan Bracket   Support de lèchefrite Soporte de bandeja de goteo   Halterung für Tropfschale
56	N710-0063	x	Drip Pan   Bac d'égouttage Bandeja de goteo   Auffangwanne
57	N510-0002	x	Bumper   Pare-chocs Tope   Stoßstange
58	N570-0128	x	Screw   Vis   Tornillo   Schraube
59	N450-0053	x	Nut   Écrou   Tuerca   Nuss
60	N450-0049	x	Nut Post   Postes d'écrous   Poste de tuerca   Nuss-Post
61	N555-0091	x	Pivot Rod   Tige pivotante Varilla pivotante   Drehzapfen
62	N485-0021	x	Pin   Épingle   Clavija   Stift
63	N010-1770-30-SS	x	Control Panel Assembly
	N010-1770-50-SS	x	Assemblage du panneau de contrôle Emsamblaje del panel de control Montage des Bedienfelds
64	N010-10001935	x	Wire Harness   Assemblage du faisceau de câbles Mazo de cables   Kabelbaum
65	N720-0044	x	Connector   Connecteur   Conector   Anschluss
66	N160-0053	x	Flex Line Clip   Clip pour ligne flexible Clip de línea flexible   Flex Line Clip
67	N660-0008LY	x	Switch   Interrupteur Interruptor   Schalter
68	N380-0040	x	Small Knob   Petit bouton Perilla pequeña   Kleiner Knopf
69	N010-1054LY	x	Small LED Bezel   Petite lunette LED Bisel LED pequeño   Kleine LED-Lünette
70	N380-0039	x	Large Knob   Grand bouton Perilla grande   Großer Knopf
71	N010-1053LY	x	Large LED Bezel   Grand cadre LED Bisel LED grande   Große LED-Lünette

Accessories Parts List  
 Liste des pièces accessoires  
 Lista de piezas de accesorios  
 Zubehör Teileliste

Part # Partie # Parte # Teil #	RP425SIB	Description   Description Descripción   Beschreibung
62050	x	Jet Fire Cleaning Kit   Kit de nettoyage Jet Fire Kit de limpieza Jet Fire   Jet Fire Reinigungsset
69912	ac	Rotisserie Kit (Europe)   Kit de rôtisserie Kit de asador   Rotisserie-Bausatz
69913	ac	Rotisserie Kit (UK)   Kit de rôtisserie Kit de asador   Rotisserie-Bausatz
69915	ac	Rotisserie Kit (Israel)   Kit de rôtisserie Kit de asador   Rotisserie-Bausatz
61427	ac	Grill Cover   Couvercle de grill Tapa de parrilla   Grillabdeckung
56425	ac	Cast Iron Griddle   Grille de cuisson en fonte Plancha de hierro fundido   Gusseisen Griddle
56093	x	Stainless Steel Griddle   Grille en acier inoxydable Plancha de acero inoxidable   Edelstahl Griddle
70030	x	Plancha Toolset   Kit d'outils Plancha Plancha Toolset   Plancha Werkzeugset
67732	ac	Charcoal/Smoker Tray   Bac à charbon/fumoir Bandeja Carbón Ahumador   Holzkohle-/Raucherammer
62007	ac	Grease Trays   Bacs à graisse Bandejas para Grasa   Fettauffangwannen
62020	ac	Drip Pan Liner   Doublure du bac de récupération Bandeja de goteo Auffangwanne Liner
S82002	ac	Premium Caster Upgrade Kit Kit de mise à niveau des roulettes Premium Kit de mejora de ruedas Premium-Nachrüstatz für Lenkrollen

\*Alternate burner for Israel.

\*Brûleur alternatif pour Israël.

\*Quemador alternativo para Israel.

\*Alternativer Brenner für Israel.



**Exploded View**  
**Vue éclatée**  
**Vista detallada**  
**Explosionszeichnung**



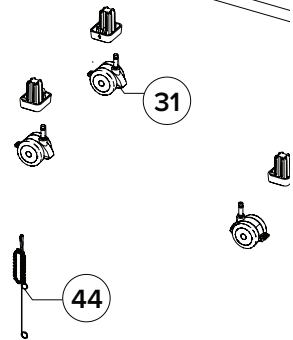
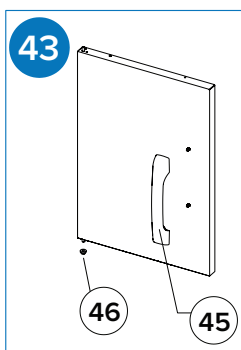
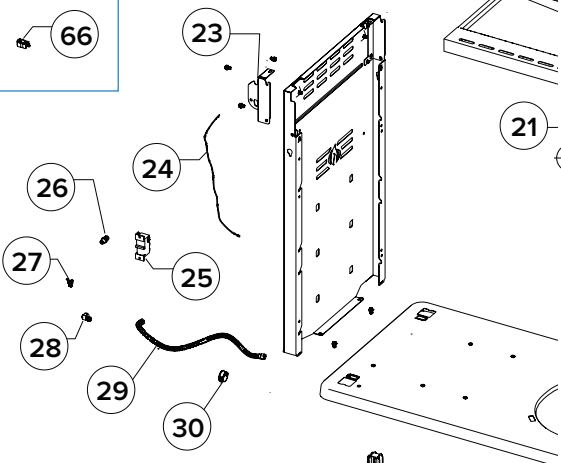
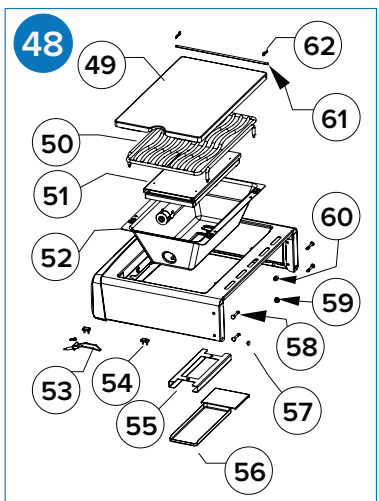
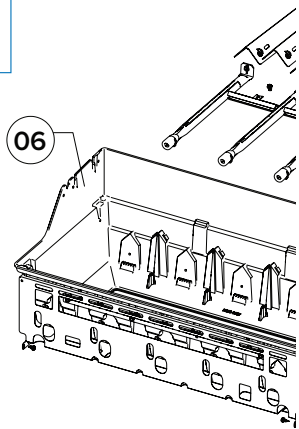
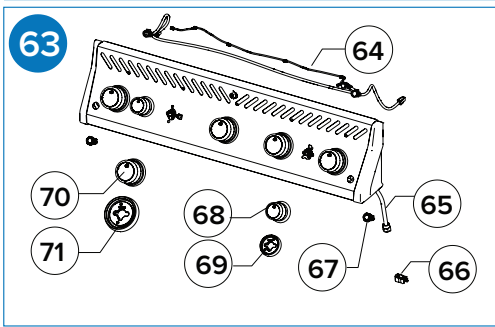
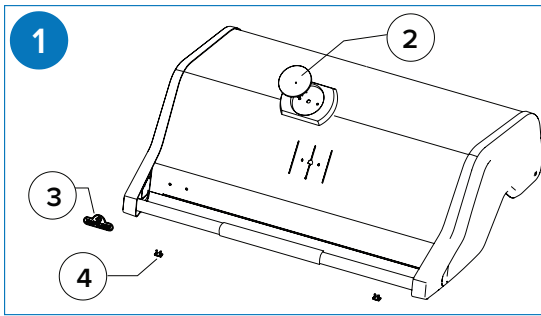

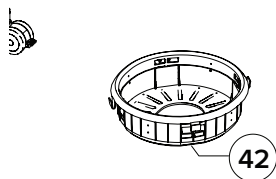
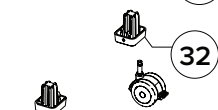
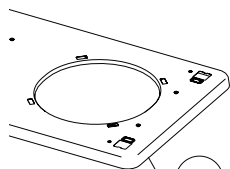
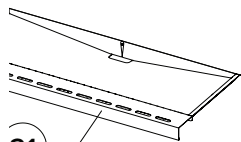
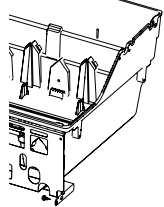
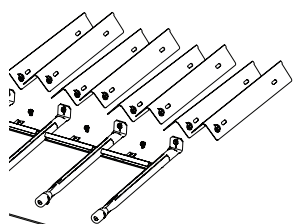

07



09



12

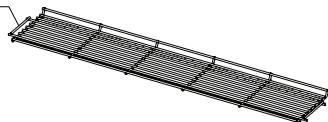

13

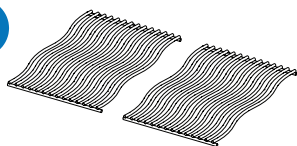

14

16

15

17

18

19

20

22

33

34

36

35

37

38

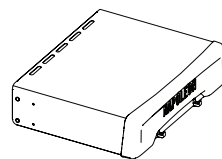

39



40



41



42



# NAPOLEON®

Celebrating over 40 years  
delivering home comfort products

Célébrant plus de 40 ans  
de produits de confort pour la maison

Celebrando más de 40 años  
entregando productos de confort para el hogar

Wir feiern über 40 Jahre  
Lieferung von Produkten für den Wohnkomfort



NAPOLEON® products are protected by one or more U.S. and Canadian and/or foreign patents or patents pending.

Les produits de NAPOLEON® sont protégés par un ou plusieurs brevets américains, canadiens et/ou étrangers au par des brevets en instance.

Los productos NAPOLEON® están protegidos por una o más patentes o patentes pendientes en E.U., Canadá y/u otros países.

NAPOLEON®-Produkte sind durch ein oder mehrere US-amerikanische und kanadische und/oder ausländische Patente oder angemeldete Patente geschützt.



**Address | Adresse  
Dirección | Adresse**

**Wolf Steel Ltd.**

De Riemsdijk 22, 4004 LC, Tiel,  
The Netherlands

10-12 Home Farm,  
Meriden Road, Berkswell,  
CV7 7SL, United Kingdom

24 Napoleon Road, Barrie, Ontario,  
L4M 0G8, Canada



**Phone | Téléphone  
Teléfono | Telefon**

**Europe**

+31 345 588655

**Online | En ligne  
En línea | On-line**

 [eu.info@napoleon.com](mailto:eu.info@napoleon.com)

 [www.napoleon.com](http://www.napoleon.com)